

1 Packing List

Please check the following items after unpacking, if any missing, please contact your local dealer.

No.	Items	Quantity
1	Switch	1pc
2	Plug Connector	1pc
3	Quick Installation Guide	1 pc

2 Safety Information

Before performing an operation, read the following operation instructions and precautions to be taken, and follow them to prevent accidents.

2.1 General Requirements

- Only qualified and skilled personnel must install, configure, and unmount the device. The device must not be disassembled.
- When operating the device, obey the local safety regulations. The safety precautions provided in the document are supplementary and shall be in compliance with the local safety regulations.
- When operating the device, in addition to the precautions (please see the notes below), follow the specific safety instructions.
- The installation and maintenance personnel need to understand the basic safety precautions to be taken.
- Do not block the ventilation while the device is running. Keep a minimum distance of 5 cm from the ventilation to the walls or the other objects that block the ventilation.
- Do not operate the device in an area that exceeds the maximum recommended ambient temperature of 75°C.
- Do not place the device in the environment that has inflammable and explosive air or fog. Do not perform any operation in this environment.

2.2 Electric Safety

- Connect the unit only to DC power source that complies with the safety extra-low voltage (SELV) requirements in IEC62368-1 based safety standards.
- Before touching the device or hand-operating parts, wear a grounded electrostatic discharge (ESD) wrist strap. It can prevent the sensitive components from damage by the static electricity in the human body.

2.3 Optical Safety

- When handling optical fibers, do not stand close to, or look at the optical fiber outlet directly with unaided eyes.
- Cutting and splicing fibers must be performed by the trained personnel only.
- Before cutting or splicing a fiber, ensure the fiber is disconnected from the optical source. After disconnecting the fiber, use protecting caps to protect all the optical connectors.

3 Product Introduction

3.1 Overview

The switch is Industrial 8-Port Gigabit PoE+ 4-Port SFP L2 Managed Ethernet Switch.

This switch provides 8 Gigabit Ethernet RJ-45 ports and 4 Gigabit SFP uplink ports. It meets IEEE 802.3af/at standard. All RJ-45 ports support Power-over-Ethernet (PoE+) and deliver up to 30W power per port.

The switch has extensive L2 management functions, such as 802.1Q VLAN, 802.1P QoS, STP/RSTP, Link aggregation, DHCP and PoE control. It can be easily managed via a WEB GUI (http/https), CLI (telnet/ssh/console) or SNMP.

3.2 Hardware Introduction

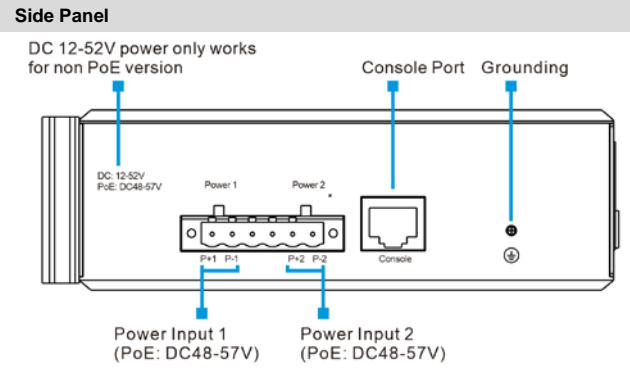
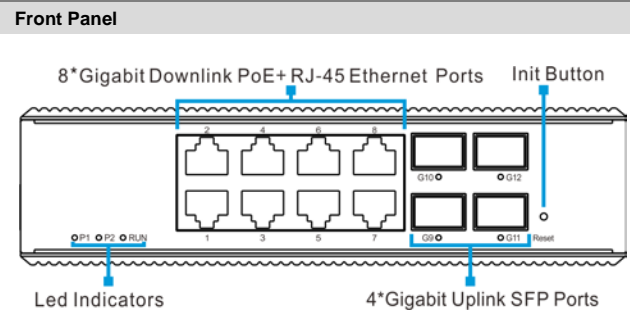

LED Indicators

Indicators	Status	Descriptions
P1	Indicator of Power 1	On: Power 1 is on. Off: Power 1 is off.
	P2	Indicator of Power 2
RUN		System indicator

Console Port

The device contains a serial RS-232 interface as the console port for local management interface. For the console port, a standard RJ-45 connector is used. Use a RS-232 cable (Sub-D9 to RJ-45) to connect the console port with the COM port of a PC.

See the default configuration in chapter "6 Factory Settings".

Init Button

The init button has two operating modes.

- By short pressing the button, the switch will be reset and the configuration is as previous setting saved.
- By pressing the button over 5s, the switch will be restored to the original factory default setting.

4 Installations

The switch supports DIN-rail installation.

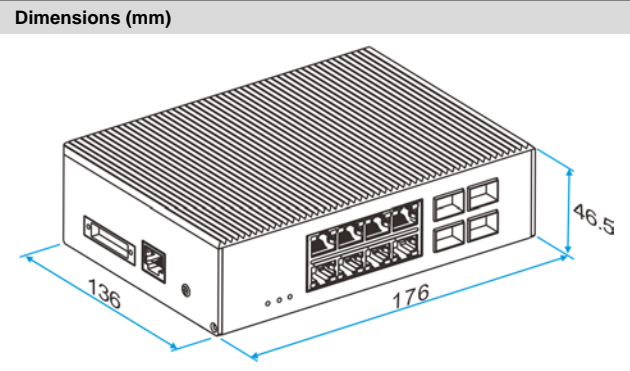

The DIN-rail hanger is fixed on the switch at the factory. Please install the switch to the DIN rail directly.

Install the switch to the DIN rail.

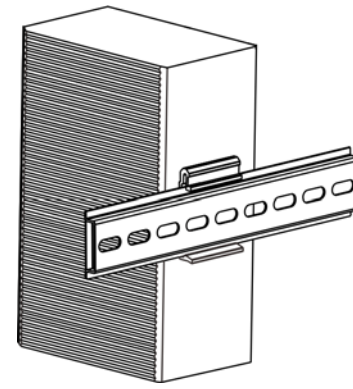

5 Connect the Power Supply

Note:

The equipment is intended to be grounded to comply with emission and immunity requirements. Ensure that the switch functional ground screw is connected to earth ground during normal use.

Use one end of GND cable to connect the M3 grounding connector of the switch, the other end to a ground point. The GND of the switch is shorted to the copper protection ground bar provided by the user. The GND cable used is recommended to be plastic insulating one with copper core, with cross-sectional area greater than 1.5mm².

Ground the switch housing

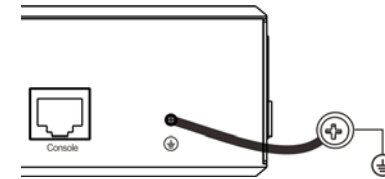

The switch is powered by a DC power connection. It supports redundant power supply.

It is possible to connect a second power source using the same voltage with the redundant power supply port. If one source fails, the alternative source takes over the power supply without interruption.

5.1 DC Supply

The power supply connectors are equipped with 6-pin plug connectors (2 NC pins in the middle of the connector). Please observe the polarity.

Use DC power cable to connect positive/negative wires of DC power separately to the "+" and "-" power terminals, using a screw driver to screwing stably. Connect the mains supply to the building's power supply network.

Connect DC power to the DC Power Connector

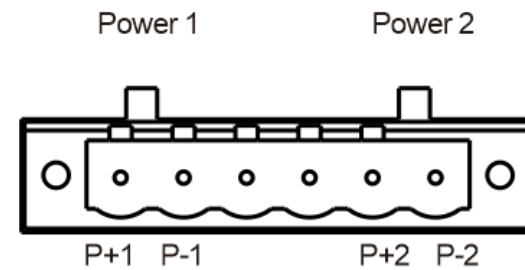

Please observe the following specifications:

Items	Specifications
wire range	24-12AWG
Solid wire (AWG)	12-24
Stranded wire (AWG)	12-24
Torque	0.4Nm (3.5Lb.in)

5.2 Starting Up

After connection to the power supply, the switch starts automatically and is ready for operation after approx. 90 s.

LED indicators "P1" or "P2" turns green.

Note:

To switch off the device, always disconnect both the main and redundant power supply.

6 Factory Settings

Note:

Please note that the factory settings may change with future firmware versions. For this reason we recommend that you check the release notes for information about any changes to the factory settings before carrying out a firmware update.

The switch starts with its factory settings:

Items	Specifications
Management Interfaces	
Console Port (Sub-D9 to RJ-45)	Enabled, Baud rate: 115200 bit/s Flow control: No flow control Parity: No parity check Stop bits: 1 Data bits: 8
SSH	Enabled
Telnet	Enabled
SNMP	Enabled
Web Manager	Enabled
User level	User: admin Password: admin Access privilege: 15 (Full access rights, This user can adjust all settings of the switch.)
IP Configuration	
default static IP address	192.168.1.200
default subnet mask	255.255.255.0
Physical Ports	
Ethernet RJ-45 ports	Ports 1-8 1000M bit/s operation enabled in VLAN 1
SFP ports	Ports G9-G12 SFP inserted: 100/1000Base-X operation

7 Access Network Management

After starting up successfully, connect the switch to your local network segment using a suitable cable to access the switch network management system. For details, please refer to one of the following documents:

- Web Configuration Guide
Describes Web network management system configuration instructions.
- CLI Configuration Guide
Describes CLI-based configuration instructions.

8 Specifications

Items	Specifications
Hardware Specifications	
Downlink Ports	8*10/100/1000Base-T PoE+ RJ-45
Uplink Ports	4*100/1000Base-X SFP
Console Port	1*RJ-45 console port
Init Button	Short press to restart the switch long press >5s to initialize the system
Led Indicators	2*power indicators 1*system indicator
Cable	Cat5 or better
Dimensions (W*D*H)	176mm*136mm*46.5mm
Net Weight	0.9kg
Input Voltage	Power 1 (Main): 48~57V DC Power 2 (Backup): 48~57V DC
Power Consumption	≤10W (Full load, not including PoE)
Installation	DIN-rail
Material	Metal shell
Switch Property	
Forwarding Modes	Store and Forward
Switching Capacity	24Gbps / non-blocking
Packet Forwarding Rate	17.9Mpps
MAC Table	8k, supported auto learning
Packet Buffer	4Mbit
Jumbo Frame	9kB
PoE	
PoE device	Endpoint PSE (Power Sourcing Equipment)
PoE Standard	IEEE 802.3af/at
PoE Pin Assignment	1/2(+), 3/6(-)
PoE Power Output	46~55V DC
PoE Budget	30W max for each port 240W max for whole switch
Standard Conformance	
Standards Compliance	IEEE 802.1p Priority Queuing IEEE 802.1Q VLAN tagging IEEE 802.1D Spanning Tree Algorithm IEEE 802.1w Rapid Spanning Tree IEEE 802.1x Authentication IEEE 802.3ad Link Aggregation IEEE 802.3x Flow Control IEEE 802.3 Ethernet IEEE 802.3u Fast Ethernet IEEE 802.3z Gigabit Ethernet IEEE 802.3af Power Over Ethernet IEEE 802.3at Power Over Ethernet
EMC	
EMC	FCC 47 CFR Part 15 Class A EN55032 Class A IEC61000-4-2, Level 3: Contact Discharge: ±8kV, Air Discharge: ±12kV IEC61000-4-3, Level 3: 10V/m IEC61000-4-4, Level 2: Power Port: ±4kV; Data Port: ±2kV IEC61000-4-5, Power Port: Line to Line ±2kV, Line to Earth ±4kV; Data Port: ±2kV IEC61000-4-6, 3V (10kHz-150kHz); 10V (150kHz-80MHz)
LVD	
LVD	EN 62368-1:2014 EN 62328-A11:2017
Environments	
Operating	Temperature: -40°C~75°C Relative Humidity: 5%~95% (Non-condensation)
Storage	Temperature: -40°C~85°C Relative Humidity: 5%~95% (Non-condensation)
Certifications	
Certifications	CE, FCC

Industrial 8-Port Gigabit PoE+ 4-Port SFP L2 Managed Ethernet Switch

Quick Installation Guide

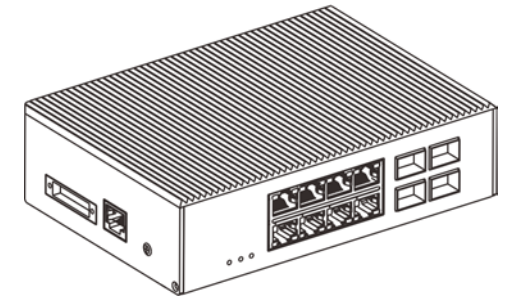

Announcement

The information in this document is subject to change without notice.

The document is only used as operation guide, except for other promises. No warranties of any kind, either express or implied are made in relation to the description, information or suggestion or any other contents of the manual.

The images shown here are indicative only. If there is inconsistency between the image and the actual product, the actual product shall govern.

Version

V1.2. Released on 2022.11.30.

Change History

Updates between document issues are cumulative. Therefore, the latest document issue contains all updates made in previous issues.

Version	State	Release Date	Description
V1.0	Released	2021-08-11	Initial commercial release.
V1.1	Released	2021-08-28	Modified "PoE Budget".
V1.2	Released	2022-11-30	Modified "Power supply connectors"